

2021Fall AMC10A

Problem 1

What is the value of $\frac{(2112 - 2021)^2}{169}$?

表达式 $\frac{(2112 - 2021)^2}{169}$ 的值是多少?

- (A) 7 (B) 21 (C) 49 (D) 64 (E) 91

Problem 2

Menkara has a 4×6 index card. If she shortens the length of one side of this card by 1 inch, the card would have area 18 square inches. What would the area of the card be in square inches if instead she shortens the length of the other side by 1 inch?

Menkara 有一张 4 英寸 \times 6 英寸的索引卡片。如果她将这张卡片一边的长度缩短 1 英寸，则该卡片的面积变为 18 平方英寸。如果她将另一边的长度缩短 1 英寸，那么卡片的面积会是多少平方英寸？

- (A) 16 (B) 17 (C) 18 (D) 19 (E) 20

Problem 3

What is the maximum number of balls of clay of radius 2 that can completely fit inside a cube of side length 6 assuming the balls can be reshaped but not compressed before they are packed in the cube?

在边长为 6 的立方体里，最多可以放入多少个半径为 2 的粘土球，这里假定球在装入立方体之前可以重塑但不能压缩？

- (A) 3 (B) 4 (C) 5 (D) 6 (E) 7

Problem 4

Mr. Lopez has a choice of two routes to get to work. Route A is 6 miles long, and his average speed along this route is 30 miles per hour. Route B is 5 miles long, and his average speed along this route is 40 miles per hour, except for a $\frac{1}{2}$ -mile stretch in a school zone where his average speed is 20 miles per hour. By how many minutes is Route B quicker than Route A?

Mr. Lopez 有两条上班路线可供选择。路线 A 长 6 英里，他沿这条路线行进的平均速度为每小时 30 英里。路线 B 长 5 英里，他沿着这条路线行进的平均速度是每小时 40 英里，除了在途经一段长为 $\frac{1}{2}$ 英里的学校附近路段时，他的平均速度是每小时 20 英里。问路线 B 比路线 A 快多少分钟？

- (A) $2\frac{3}{4}$ (B) $3\frac{3}{4}$ (C) $4\frac{1}{2}$ (D) $5\frac{1}{2}$ (E) $6\frac{3}{4}$

Problem 5

The six-digit number $\underline{20210A}$ is prime for only one digit A . What is A ?

使得六位数 $\underline{20210A}$ 是素数的数字 A 只有一个。问 A 是几？

- (A) 1 (B) 3 (C) 5 (D) 7 (E) 9

Problem 6

Elmer the emu takes 44 equal strides to walk between consecutive telephone poles on a rural road. Oscar the ostrich can cover the same distance in 12 equal leaps. The telephone poles are evenly spaced, and the 41st pole along this road is exactly one mile (5280 feet) from the first pole. How much longer, in feet, is Oscar's leap than Elmer's stride?

鸸 Elmer 在乡村道路上的相邻电线杆之间行走需要步幅相同的 44 步。同样的距离，鸵鸟 Oscar 只需要 12 次等距的跳跃。电线杆均匀分布，从第 1 根电线杆到第 41 根电线杆的距离正好是一英里（5280 英尺）。问 Oscar 的一跳比 Elmer 的一步长多少英尺？

- (A) 6 (B) 8 (C) 10 (D) 11 (E) 15

Problem 7

As shown in the figure below, point E lies on the opposite half-plane determined by line CD from point A so that $\angle CDE = 110^\circ$. Point F lies on \overline{AD} so that $DE = DF$, and $ABCD$ is a square. What is the degree measure of $\angle AFE$?

如下图所示，点 E 位于由直线 CD 确定的与点 A 相对的半平面上，使得 $\angle CDE = 110^\circ$ 。点 F 位于 \overline{AD} 上，使得 $DE = DF$ ，并且 $ABCD$ 是一个正方形。问 $\angle AFE$ 的度数是多少？

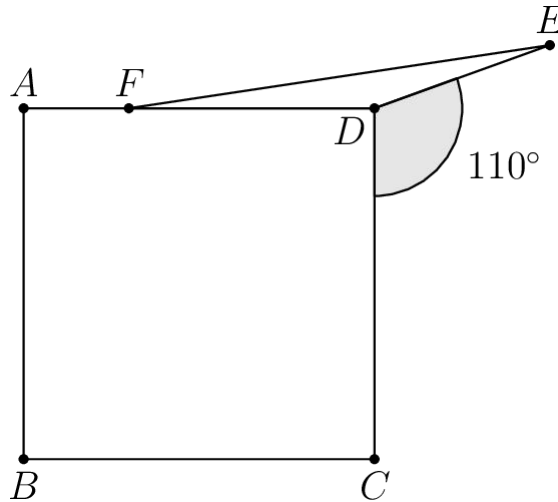

- (A) 160 (B) 164 (C) 166 (D) 170 (E) 174

Problem 8

A two-digit positive integer is said to be *cuddly* if it is equal to the sum of its nonzero tens digit and the square of its units digit. How many two-digit positive integers are cuddly?

如果一个两位正整数等于它的非零十位数字与它的个位数字的平方之和，则称它为“可爱的”。问有多少个两位正整数是可爱的？

- (A) 0 (B) 1 (C) 2 (D) 3 (E) 4

Problem 9

When a certain unfair die is rolled, an even number is 3 times as likely to appear as an odd number. The die is rolled twice. What is the probability that the sum of the numbers rolled is even?

当抛掷某个不均匀的骰子时，偶数出现的可能性是奇数的 3 倍。抛掷骰子两次。掷出数的和为偶数的概率是多少？

- (A) $\frac{3}{8}$ (B) $\frac{4}{9}$ (C) $\frac{5}{9}$ (D) $\frac{9}{16}$ (E) $\frac{5}{8}$

Problem 10

A school has 100 students and 5 teachers. In the first period, each student is taking one class, and each teacher is teaching one class. The enrollments in the classes are 50, 20, 20, 5, and 5. Let t be the average value obtained if a teacher is picked at random and the number of students in their class is noted. Let s be the average value obtained if a student was picked at random and the number of students in their class, including the student, is noted. What is $t - s$?

一所学校有 100 名学生和 5 名教师。在第一期，每个学生选一门课，每个老师教一门课。各课程的注册人数为 50、20、20、5 和 5。如果按随机挑选一名教师，并记录他的班级学生人数的方式进行统计，所得的平均值为 t 。如果按随机挑选一名学生，并记录该学生所在的班级学生人数的方式进行统计，所获得的平均值为 s 。问 $t - s$ 是多少？

- (A) -18.5 (B) -13.5 (C) 0 (D) 13.5 (E) 18.5

Problem 11

Emily sees a ship traveling at a constant speed along a straight section of a river. She walks parallel to the riverbank at a uniform rate faster than the ship. She counts 210 equal steps walking from the back of the ship to the front. Walking in the opposite direction, she counts 42 steps of the same size from the front of the ship to the back. In terms of Emily's equal steps, what is the length of the ship?

Emily 看到一艘沿着一段笔直的河道匀速行驶的船。她以比船快的固定速度平行于河岸行走。她数出，从船尾走到船头，共用了 210 步。如果她朝相反的方向走，按同样的步长，从船头走到船尾只需 42 步。以 Emily 每步都相同的步长为单位，船的长度是多少？

- (A) 70 (B) 84 (C) 98 (D) 105 (E) 126

Problem 12

The base-nine representation of the number N is $27,006,000,052_{\text{nine}}$. What is the remainder when N is divided by 5?

数 N 的九进制表示是 $27,006,000,052_9$ 。问 N 除以 5 的余数是多少？

- (A) 0 (B) 1 (C) 2 (D) 3 (E) 4

Problem 13

Each of 6 balls is randomly and independently painted either black or white with equal probability. What is the probability that every ball is different in color from more than half of the other 5 balls?

6 个球中的每一个球以相同的概率随机并独立的被涂成黑色或白色。每个球与其他 5 个球中的一半以上颜色不同的概率是多少？

- (A) $\frac{1}{64}$ (B) $\frac{1}{6}$ (C) $\frac{1}{4}$ (D) $\frac{5}{16}$ (E) $\frac{1}{2}$

Problem 14

How many ordered pairs (x, y) of real numbers satisfy the following system of equations?

$$\begin{aligned}x^2 + 3y &= 9 \\ (|x| + |y| - 4)^2 &= 1\end{aligned}$$

满足以下方程组的有序实数对 (x, y) 有多少个？

$$\begin{aligned}x^2 + 3y &= 9 \\ (|x| + |y| - 4)^2 &= 1\end{aligned}$$

- (A) 1 (B) 2 (C) 3 (D) 5 (E) 7

Problem 15

Isosceles triangle ABC has $AB = AC = 3\sqrt{6}$, and a circle with radius $5\sqrt{2}$ is tangent to line AB at B and to line AC at C . What is the area of the circle that passes through vertices A , B , and C ?

在等腰三角形 ABC 中 $AB = AC = 3\sqrt{6}$ ，并且半径为 $5\sqrt{2}$ 的圆与直线 AB 在 B 处相切，与直线 AC 在 C 处相切。问通过顶点 A 、 B 和 C 的圆的面积是多少？

- (A) 24π (B) 25π (C) 26π (D) 27π (E) 28π

Problem 16

The graph of $f(x) = \lfloor x \rfloor - \lfloor 1 - x \rfloor$ is symmetric about which of the following? (Here $\lfloor x \rfloor$ is the greatest integer not exceeding x .)

- (A) the y -axis (B) the line $x = 1$ (C) the origin (D) the point $\left(\frac{1}{2}, 0\right)$ (E) the point $(1, 0)$

$f(x) = \lfloor x \rfloor - \lfloor 1 - x \rfloor$ 的图像关于什么对称? (这里 $\lfloor x \rfloor$ 表示不超过 x 的最大整数。)

- (A) y 轴 (B) 直线 $x=1$ (C) 原点 (D) 点 $\left(\frac{1}{2}, 0\right)$ (E) 点 $(1, 0)$

Problem 17

An architect is building a structure that will place vertical pillars at the vertices of regular hexagon $ABCDEF$, which is lying horizontally on the ground. The six pillars will hold up a flat solar panel that will not be parallel to the ground. The heights of pillars at A , B , and C are 12, 9, and 10 meters, respectively. What is the height, in meters, of the pillar at E ?

一位建筑师正在建造一个构型，该构型将垂直的柱子放置在地面上水平的正六边形 $ABCDEF$ 的顶点处。六根柱子将支撑一块与地面不平行的呈平面状的太阳能电池板。 A 、 B 和 C 处的柱子高度分别为 12、9 和 10 米。问 E 处的柱子高度是多少米?

- (A) 9 (B) $6\sqrt{3}$ (C) $8\sqrt{3}$ (D) 17 (E) $12\sqrt{3}$

Problem 18

A farmer's rectangular field is partitioned into 2 by 2 grid of 4 rectangular sections as shown in the figure. In each section the farmer will plant one crop: corn, wheat, soybeans, or potatoes. The farmer does not want to grow corn and wheat in any two sections that share a border, and the farmer does not want to grow soybeans and potatoes in any two sections that share a border. Given these restrictions, in how many ways can the farmer choose crops to plant in each of the four sections of the field?

如图所示，一个农民的矩形田地按 2×2 的网格被划分为 4 个矩形部分。在每个部分，农民将种植一种作物：玉米、小麦、大豆或马铃薯。农民不想在任何两个有公共边界的部分种植玉米和小麦，农民也不想在任何两个有公共边界的部分种植大豆和马铃薯。基于这些限制，农民在田地的四个部分中安排要种植的作物有多少种方式？



- (A) 12 (B) 64 (C) 84 (D) 90 (E) 144

Problem 19

A disk of radius 1 rolls all the way around the inside of a square of side length $s > 4$ and sweeps out a region of area A . A second disk of radius 1 rolls all the way around the outside of the same square and sweeps out a region of area $2A$. The value of s can be written as $a + \frac{b\pi}{c}$, where a, b , and c are positive integers and b and c are relatively prime. What is $a + b + c$?

半径为 1 的圆盘在边长 $s > 4$ 的正方形的内侧滚动，它所经过的区域的面积为 A 。半径为 1 的第二个圆盘绕着同一个正方形的外侧滚动，它所经过的区域的面积为 $2A$ 。 s 的值可以写成

$a + \frac{b\pi}{c}$ ，其中 a, b 和 c 是正整数， b 和 c 互素。问 $a+b+c$ 是多少？

- (A) 10 (B) 11 (C) 12 (D) 13 (E) 14

Problem 20

How many ordered pairs of positive integers (b, c) exist where

both $x^2 + bx + c = 0$ and $x^2 + cx + b = 0$ do not have distinct, real solutions?

使得 $x^2 + bx + c = 0$ 与 $x^2 + cx + b = 0$ 都没有两个不同的实数解的有序正整数对 (b, c) 有多少个?

- (A) 4 (B) 6 (C) 8 (D) 10 (E) 12

Problem 21

Each of the 20 balls is tossed independently and at random into one of the 5 bins. Let p be the probability that some bin ends up with 3 balls, another with 5 balls, and the other three with 4 balls

each. Let q be the probability that every bin ends up with 4 balls. What is q ?

20 个球中的每一个被独立并随机的扔进 5 个桶中的一个。设 p 是最终一个桶中有 3 个球，另一个桶中有 5 个球，并且其余的三个桶中各有 4 个球的概率。 q 是最终每个桶中有 4 个球的概

率。问 q 是多少?

- (A) 1 (B) 4 (C) 8 (D) 12 (E) 16

Problem 22

Inside a right circular cone with base radius 5 and height 12 are three congruent spheres with radius r . Each sphere is tangent to the other two spheres and also tangent to the base and side of the cone. What is r ?

在底面半径为 5、高度为 12 的正圆锥内有三个相同的球体，每个球体的半径为 r 。每个球体都与其他两个球体相切，并且还和圆锥的底面和侧面相切。问 r 是多少?

- (A) $\frac{3}{2}$ (B) $\frac{90 - 40\sqrt{3}}{11}$ (C) 2 (D) $\frac{144 - 25\sqrt{3}}{44}$ (E) $\frac{5}{2}$

Problem 23

For each positive integer n , let $f_1(n)$ be twice the number of positive integer divisors of n , and for $j \geq 2$, let $f_j(n) = f_1(f_{j-1}(n))$. For how many values of $n \leq 50$ is $f_{50}(n) = 12$?

对于每个正整数 n ，令 $f_1(n)$ 是 n 的正整数约数个数的两倍，并且对于 $j \geq 2$ ，令 $f_j(n) = f_1(f_{j-1}(n))$ 。对于 $n \leq 50$ ，满足 $f_{50}(n) = 12$ 的 n 值有多少个？

- (A) 7 (B) 8 (C) 9 (D) 10 (E) 11

Problem 24

Each of the 12 edges of a cube is labeled 0 or 1. Two labelings are considered different even if one can be obtained from the other by a sequence of one or more rotations and/or reflections. For how many such labelings is the sum of the labels on the edges of each of the 6 faces of the cube equal to 2?

立方体的 12 条边的每一条都标有 0 或 1，一种标记方法即使可以通过一系列的旋转或者反射由另一种标记方法得到，两种标记方法也认为是不同的。问使得立方体的 6 个面中每个面的各条边上所标数的总和等于 2 的方法有多少种？

- (A) 8 (B) 10 (C) 12 (D) 16 (E) 20

Problem 25

A quadratic polynomial with real coefficients and leading coefficient 1 is called *disrespectful* if the equation $p(p(x)) = 0$ is satisfied by exactly three real numbers. Among all the disrespectful quadratic polynomials, there is a unique such polynomial $\tilde{p}(x)$ for which the sum of the roots is maximized. What is $\tilde{p}(1)$?

如果恰好有三个实数满足方程 $p(p(x)) = 0$ ，那么首项系数为 1 的实系数二次多项式 $p(x)$ 被称为“不受尊重的”。在所有不受尊重的二次多项式中，有唯一的多项式 $\tilde{p}(x)$ 使得其各根之和取最大值。问 $\tilde{p}(1)$ 是多少？

- (A) $\frac{5}{16}$ (B) $\frac{1}{2}$ (C) $\frac{5}{8}$ (D) 1 (E) $\frac{9}{8}$

2021Fall AMC 10A Answer Key

1	2	3	4	5	6	7	8	9	10	11	12	13
C	E	D	B	E	B	D	B	E	B	A	D	D
14	15	16	17	18	19	20	21	22	23	24	25	
D	C	D	D	C	A	B	E	B	D	E	A	