

2009 AMC8**Problem 1**

Bridget bought a bag of apples at the grocery store. She gave half of the apples to Ann. Then she gave Cassie 3 apples, keeping 4 apples for herself. How many apples did Bridget buy?

Bridget 在水果店买了一包苹果。她把一半苹果给了 Ann，然后她把 3 个苹果给了 Cassie，自己留了 4 个。那么 Bridget 总共买了多少个苹果？

- (A) 3 (B) 4 (C) 7 (D) 11 (E) 14

Problem 2

On average, for every 4 sports cars sold at the local dealership, 7 sedans are sold. The dealership predicts that it will sell 28 sports cars next month. How many sedans does it expect to sell?

平均下来，当地经销商每售出 4 辆跑车，就售出 7 辆轿车。该经销商预计下个月将销售 28 辆跑车，那么预计销售多少辆轿车？

- (A) 7 (B) 32 (C) 35 (D) 49 (E) 112

Problem 3

The graph shows the constant rate at which Suzanna rides her bike. If she rides a total of a half an hour at the same speed, how many miles would she have ridden?

下图显示了 Suzanna 以恒定的速度骑自行车。如果她以同样的速度骑了半个小时，她将骑多少英里？

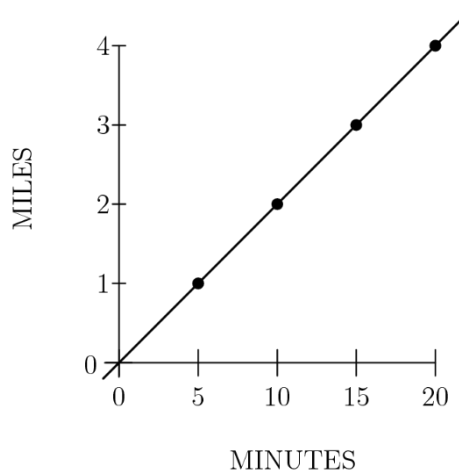

- (A) 5 (B) 5.5 (C) 6 (D) 6.5 (E) 7

Problem 4

The five pieces shown below can be arranged to form four of the five figures shown in the choices. Which figure cannot be formed?

下面所示的 5 个图形可以重新组合成 5 个选项里其中 4 个图形。那么哪个选项里的图形无法形成？

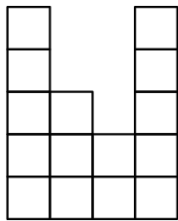
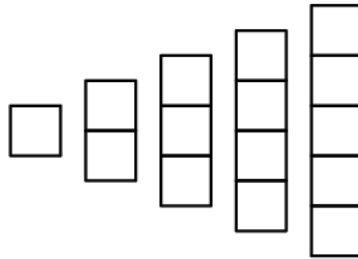

(A)

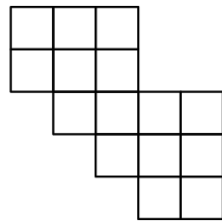

(B)

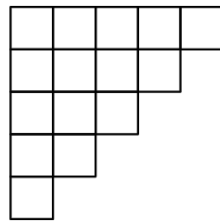

(C)

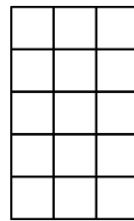

(D)

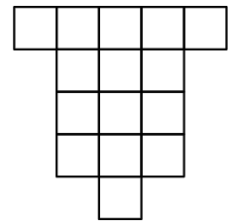

(E)

Problem 5

A sequence of numbers starts with 1, 2, and 3. The fourth number of the sequence is the sum of the previous three numbers in the sequence: $1 + 2 + 3 = 6$. In the same way, every number after the fourth is the sum of the previous three numbers. What is the eighth number in the sequence?

某个数列以 1, 2 和 3 开头。第四项是数列里前 3 项之和: $1 + 2 + 3 = 6$ 。类似的, 第 4 项之后的每一项都是这一项之前的 3 项之和。那么这个数列的第 8 项是多少?

- (A) 11 (B) 20 (C) 37 (D) 68 (E) 99

Problem 6

Steve's empty swimming pool will hold 24,000 gallons of water when full. It will be filled by 4 hoses, each of which supplies 2.5 gallons of water per minute. How many hours will it take to fill Steve's pool?

Steve 家的游泳池当装满水时，能装 24,000 加仑的水。现在将由 4 个水管同时灌水，每个水管每分钟灌水 2.5 加仑。那么将 Steve 家的泳池灌满水要多少小时？

- (A) 40 (B) 42 (C) 44 (D) 46 (E) 48

Problem 7

The triangular plot of ACD lies between Aspen Road, Brown Road and a railroad. Main Street runs east and west, and the railroad runs north and south. The numbers in the diagram indicate distances in miles. The width of the railroad track can be ignored. How many square miles are in the plot of land ACD?

三角形 ACD 区域处于 Aspen 公路，Brown 公路和一条铁路之间。Main 街道是东西向，铁路是南北向。图中的数字表示以英里为单位的距离。铁路轨道的宽度可以忽略。那么区域 ACD 的面积是多少平方英里？

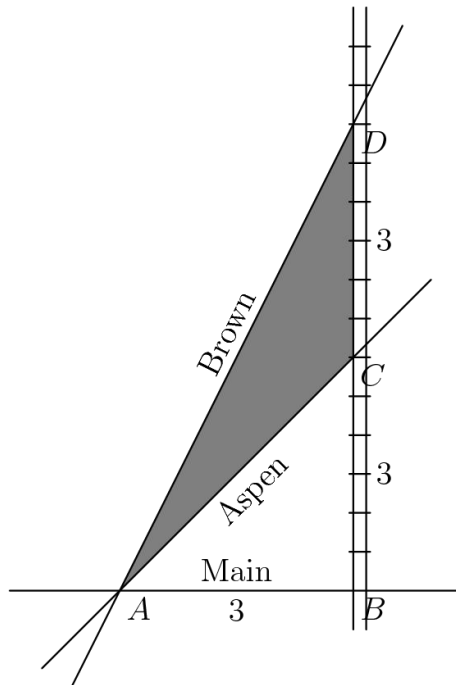

- (A) 2 (B) 3 (C) 4.5 (D) 6 (E) 9

Problem 8

The length of a rectangle is increased by 10% and the width is decreased by 10%. What percent of the old area is the new area?

矩形的长增加了 10%，宽减小了 10%，那么新的矩形面积是原来的面积的百分之多少？

- (A) 90 (B) 99 (C) 100 (D) 101 (E) 110

Problem 9

Construct a square on one side of an equilateral triangle. On a non-adjacent side of the square, construct a regular pentagon, as shown. On a non-adjacent side of the pentagon, construct a hexagon. Continue to construct regular polygons in the same way, until you construct an octagon. How many sides does the resulting polygon have?

在一个等边三角形的一边上作一个正方形，然后在此正方形的另一条非相邻边上作一个正五边形，如下图所示。再在此五边形的一条非相邻边上作一个六边形。按照这种方法不断作出正多边形，直到作出一个八边形。那么最终形成的多边形有多少条边？

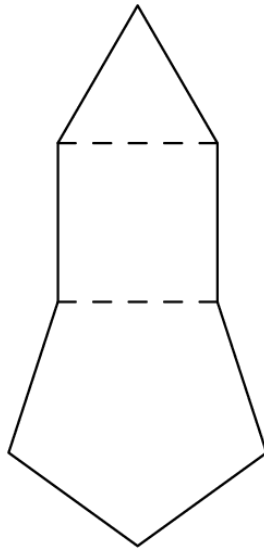

- (A) 21 (B) 23 (C) 25 (D) 27 (E) 29

Problem 10

On a checkerboard composed of 64 unit squares, what is the probability that a randomly chosen unit square does not touch the outer edge of the board?

在由 64 个单位正方形组成的棋盘上随机选择一个单位正方形，那么此单位正方形不接触棋盘外缘的概率是多少？

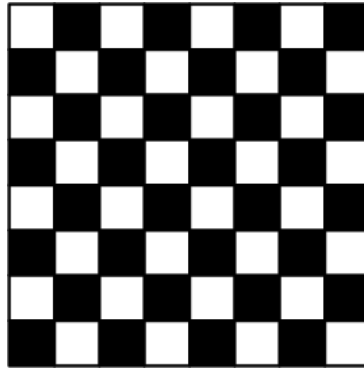

- (A) $\frac{1}{16}$ (B) $\frac{7}{16}$ (C) $\frac{1}{2}$ (D) $\frac{9}{16}$ (E) $\frac{49}{64}$

Problem 11

The Amaco Middle School bookstore sells pencils costing a whole number of cents. Some seventh graders each bought a pencil, paying a total of \$1.43. Some of the 30 sixth graders each bought a pencil, and they paid a total of \$1.95. How many more sixth graders than seventh graders bought a pencil?

Amaco 中学的书店所卖的铅笔每根的价格是个整数（单位：美分）。一些七年级学生每个人买了一支铅笔，总共花了 1.43 美元。一些六年级学生（不超过 30 人）每人买了一支铅笔，总共花了 1.95 美元。买铅笔的人当中，六年级学生比七年级多多少人？

- (A) 1 (B) 2 (C) 3 (D) 4 (E) 5

Problem 12

The two spinners shown are spun once and each lands on one of the numbered sectors. What is the probability that the sum of the numbers in the two sectors is prime?

如下所示的两个转盘各自转一次，每个转盘落在各自的某个扇形区域上。那么落在的这两个扇形区域的数字之和是个质数的概率是多少？

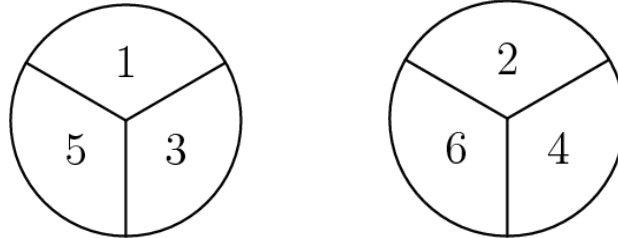

- (A) $\frac{1}{2}$ (B) $\frac{2}{3}$ (C) $\frac{3}{4}$ (D) $\frac{7}{9}$ (E) $\frac{5}{6}$

Problem 13

A three-digit integer contains one of each of the digits 1, 3, and 5. What is the probability that the integer is divisible by 5?

一个三位整数包含了数字 1, 3 和 5, 且每个出现一次。那么这个整数能被 5 整除的概率是多少？

- (A) $\frac{1}{6}$ (B) $\frac{1}{3}$ (C) $\frac{1}{2}$ (D) $\frac{2}{3}$ (E) $\frac{5}{6}$

Problem 14

Austin and Temple are 50 miles apart along Interstate 35. Bonnie drove from Austin to her daughter's house in Temple, averaging 60 miles per hour. Leaving the car with her daughter, Bonnie rode a bus back to Austin along the same route and averaged 40 miles per hour on the return trip. What was the average speed for the round trip, in miles per hour?

奥斯汀和坦普尔沿 35 号州际公路相距 50 英里。Bonnie 从奥斯汀开车到她女儿位于坦普尔的家，平均时速为 60 英里。Bonnie 之后把车留给了女儿，接着沿着同一条路线乘公共汽车返回奥斯汀，回程平均速度为每小时 40 英里。那么她往返的平均速度是多少英里每小时？

- (A) 46 (B) 48 (C) 50 (D) 52 (E) 54

Problem 15

A recipe that makes 5 servings of hot chocolate requires 2 squares of chocolate, $\frac{1}{4}$ cup sugar, 1 cup water and 4 cups milk. Jordan has 5 squares of chocolate, 2 cups of sugar, lots of water and 7 cups of milk. If she maintains the same ratio of ingredients, what is the greatest number of servings of hot chocolate she can make?

一种制作 5 份热巧克力的配方需要 2 块巧克力、 $\frac{1}{4}$ 杯糖、1 杯水和 4 杯牛奶。乔丹有 5 块巧克力，2 杯糖，大量的水和 7 杯牛奶。如果她保持相同的配料比例，那么她能做的热巧克力的最大份数是多少？

- (A) $5\frac{1}{8}$ (B) $6\frac{1}{4}$ (C) $7\frac{1}{2}$ (D) $8\frac{3}{4}$ (E) $9\frac{7}{8}$

Problem 16

How many 3-digit positive integers have digits whose product equals 24?

有多少个 3 位正整数，满足各个位上数字之积是 24？

- (A) 12 (B) 15 (C) 18 (D) 21 (E) 24

Problem 17

The positive integers x and y are the two smallest positive integers for which the product of 360 and x is a square and the product of 360 and y is a cube. What is the sum of x and y ?

x 和 y 是满足 360 和 x 之积为平方数，360 和 y 之积为立方数的最小正整数。那么 x 和 y 的和是多少？

- (A) 80 (B) 85 (C) 115 (D) 165 (E) 610

Problem 18

The diagram represents a 7-foot-by-7-foot floor that is tiled with 1-square-foot black tiles and white tiles. Notice that the corners have white tiles. If a 15-foot-by-15-foot floor is to be tiled in the same manner, how many white tiles will be needed?

该图表示一块 7 英尺乘 7 英尺的地板，该地板由 1 平方英尺的黑色瓷砖和白色瓷砖铺成。请注意，四个角都是白色瓷砖。如果某个 15 英尺乘 15 英尺的地板要以同样的方式铺成，需要多少块白色瓷砖？

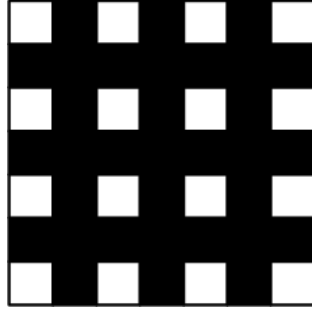

- (A) 49 (B) 57 (C) 64 (D) 96 (E) 126

Problem 19

Two angles of an isosceles triangle measure 70° and x° . What is the sum of the three possible values of x ?

一个等腰三角形其中两个角的度数是 70° 和 x° 。那么 x 的 3 个可能值之和是多少？

- (A) 95 (B) 125 (C) 140 (D) 165 (E) 180

Problem 20

How many non-congruent triangles have vertices at three of the eight points in the array shown below?

以下图所示阵列 8 个，点中的 3 个为顶点，可以形成多少个不全等的三角形？

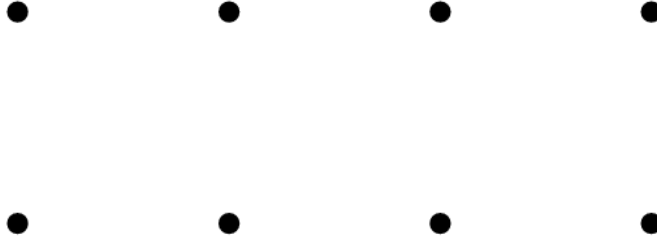

- (A) 5 (B) 6 (C) 7 (D) 8 (E) 9

Problem 21

Andy and Bethany have a rectangular array of numbers with 40 rows and 75 columns. Andy adds the numbers in each row. The average of his 40 sums is A . Bethany adds the numbers in each column.

The average of her 75 sums is B . What is the value of $\frac{A}{B}$?

Andy 和 Bethany 有一张 40 行 75 列的矩形正数阵列，Andy 把每行的数字都相加，得到的 40

个和的平均值是 A 。Bethany 把每列的数字都相加，所得的 75 个和的平均值是 B 。那么 $\frac{A}{B}$ 的值是多少？

- (A) $\frac{64}{225}$ (B) $\frac{8}{15}$ (C) 1 (D) $\frac{15}{8}$ (E) $\frac{225}{64}$

Problem 22

How many whole numbers between 1 and 1000 do not contain the digit 1?

1 和 1000 之间有多少个整数不含有数字 1？

- (A) 512 (B) 648 (C) 720 (D) 728 (E) 800

Problem 23

On the last day of school, Mrs. Wonderful gave jelly beans to her class. She gave each boy as many jelly beans as there were boys in the class. She gave each girl as many jelly beans as there were girls in the class. She brought 400 jelly beans, and when she finished, she had six jelly beans left. There were two more boys than girls in her class. How many students were in her class?

在学期的最后一天，苏威太太给全班同学送去了果冻豆。她给每个男孩的果冻豆数量和班上男孩的数量一样多，她给每个女孩的果冻豆数量和班上女孩的数量一样多。她一共带了 400 颗果冻豆，当她发完时，她还剩下 6 个果冻豆。她班上男生比女生多两个。她班上有多少学生？

- (A) 26 (B) 28 (C) 30 (D) 32 (E) 34

Problem 24

The letters A , B , C and D represent digits. If $\begin{array}{r} A \ B \\ + \ C \ A \\ \hline D \ A \end{array}$ and $\begin{array}{r} A \ B \\ - \ C \ A \\ \hline A \end{array}$, what digit does D represent?

字母 A , B , C 和 D 代表数字。若 $\begin{array}{r} A \ B \\ + \ C \ A \\ \hline D \ A \end{array}$ ，且 $\begin{array}{r} A \ B \\ - \ C \ A \\ \hline A \end{array}$ ，那么 D 代表的数字是多少？

- (A) 5 (B) 6 (C) 7 (D) 8 (E) 9

Problem 25

A one-cubic-foot cube is cut into four pieces by three cuts parallel to the top face of the cube. The first cut is $\frac{1}{2}$ foot from the top face. The second cut is $\frac{1}{3}$ foot below the first cut, and the third cut is $\frac{1}{17}$ foot below the second cut. From the top to the bottom the pieces are labeled A, B, C, and D. The pieces are then glued together end to end as shown in the second diagram. What is the total surface area of this solid in square feet?

一个 1 立方英尺的正方体被平行于立方体顶面的三个切口切成四块。第一个切口距离顶面 $\frac{1}{2}$ 英尺。第二个切口比第一个切口低 $\frac{1}{3}$ 英尺，第三个切口比第二个切口低 $\frac{1}{17}$ 英尺。从上到下，切出的这 4 块立体图形被标记为 A、B、C 和 D。接着这 4 块立体图形被一个接一个地粘合在一起，如第二张图所示。那么新形成的立体图形的总表面积是多少平方英尺？

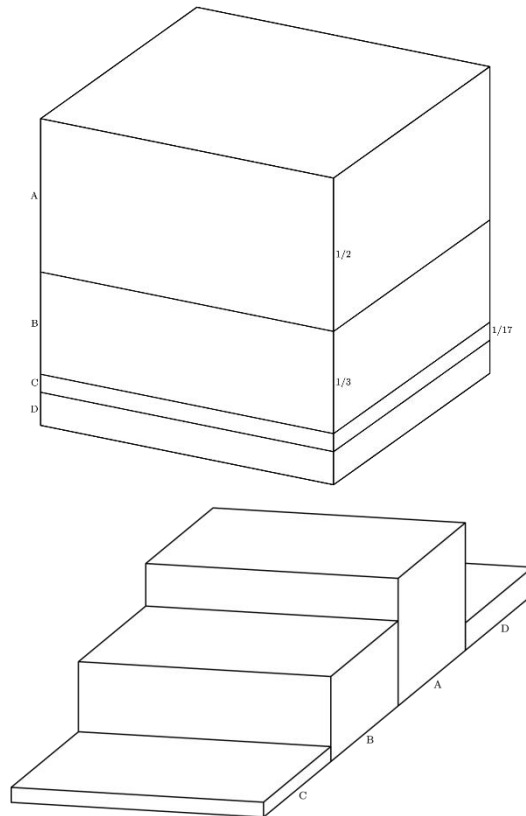

- (A) 6 (B) 7 (C) $\frac{419}{51}$ (D) $\frac{158}{17}$ (E) 11

2009 AMC 8 Answer Key

1	2	3	4	5	6	7	8	9	10	11	12	13
E	D	C	B	D	A	C	B	B	D	D	D	B
14	15	16	17	18	19	20	21	22	23	24	25	
B	D	D	B	C	D	D	D	D	B	E	E	